

STRUCTURAL STEEL STORAGE RACK

Structural Beam Type

STANDARD BEAM - AA (Flanges In)

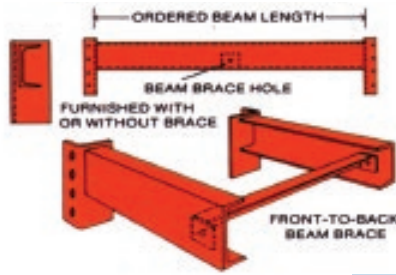

ALTERNATE BEAM - BA (Flanges Out)

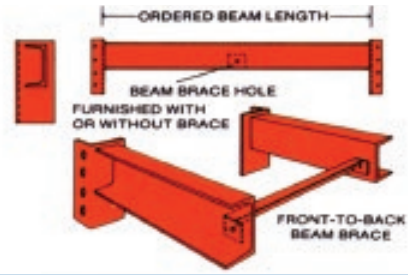

Structural Upright Capacities

BOTTOM BEAM SPACING	33	34	44	45
	3"	3"	4"	4"
36	33,900	37,100	50,500	55,800
42	33,700	36,900	49,900	55,300
48	33,500	36,700	49,300	54,900
54	33,400	36,600	48,800	54,600
60	33,300	36,500	48,400	54,300
66	33,000	34,300	48,100	54,100
72	29,300	30,300	47,900	53,900
78	25,800	26,500	47,600	52,800
84	22,500	22,900	46,100	48,700
90	19,500	19,900	42,500	44,600
96	17,100	17,400	39,000	40,600

- NOTES:
- Capacities are based on the 2012 RMI Specification and the 2010 AISC Specification.
 - Capacities listed are valid for stored product load and typical dead load only. For any other loading condition, including seismic, contact Engineering for design and capacities.
 - Capacities shown are based on the beam spacing from the floor to the top of the first beam level. Add 3' to the beam spacing to determine the upright capacity between beam levels.
 - For beam spacings greater than 96", contact Engineering.
 - Upright capacities are based on rack anchored and installed per the RMI Specification and for standard upright bracing for upright depths 36" to 60". For upright depths outside this range, contact Engineering for bracing, anchorage and base plate design.
 - Capacities below bold lines are governed by deflection.

Structural Upright Part Number

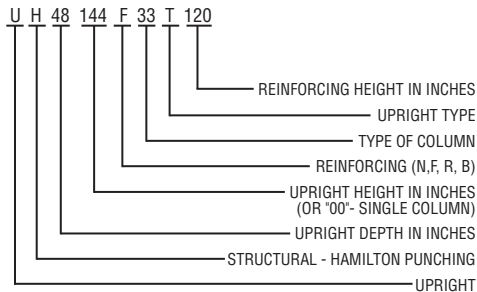

BEAMS

STRUCTURAL BRACED BEAM CAPACITIES

LENGTH	33H		34H		44H		45H		56H		68H	
	CAP'Y	DEFL	CAP'Y	DEFL	CAP'Y	DEFL	CAP'Y	DEFL	CAP'Y	DEFL	CAP'Y	DEFL
48	12,260	0.18	13,020	0.18	20,000	0.13	20,000	0.12	20,000	0.06	20,000	0.04
54	10,940	0.23	11,640	0.23	18,300	0.17	19,730	0.17	20,000	0.09	20,000	0.05
60	9,900	0.28	10,540	0.29	16,530	0.21	17,820	0.21	20,000	0.13	20,000	0.07
66	9,050	0.34	9,640	0.35	15,090	0.25	16,260	0.26	20,000	0.17	20,000	0.10
72	8,200	0.40	8,620	0.40	13,880	0.30	14,960	0.31	20,000	0.22	20,000	0.12
78	7,040	0.43	7,390	0.43	12,860	0.35	13,860	0.36	20,000	0.27	20,000	0.16
84	6,110	0.47	6,420	0.47	11,990	0.41	12,910	0.42	19,670	0.34	20,000	0.20
90	5,360	0.50	5,630	0.50	11,230	0.47	12,090	0.48	18,400	0.39	20,000	0.24
92	5,140	0.51	5,400	0.51	11,000	0.49	11,840	0.50	18,010	0.40	20,000	0.26
94	4,930	0.52	5,180	0.52	10,770	0.51	11,550	0.52	17,640	0.42	20,000	0.28
96	4,740	0.53	4,980	0.53	10,550	0.53	11,090	0.53	17,290	0.44	20,000	0.29
98	4,560	0.54	4,790	0.54	10,140	0.54	10,660	0.54	16,950	0.46	20,000	0.31
100	4,390	0.56	4,610	0.56	9,750	0.56	10,250	0.56	16,620	0.48	20,000	0.33
102	4,230	0.57	4,440	0.57	9,390	0.57	9,860	0.57	16,310	0.49	20,000	0.35
104	4,070	0.58	4,280	0.58	9,040	0.58	9,500	0.58	16,010	0.51	20,000	0.37
106	3,930	0.59	4,130	0.59	8,720	0.59	9,160	0.59	15,720	0.53	20,000	0.39
108	3,800	0.60	3,990	0.60	8,410	0.60	8,830	0.60	15,440	0.55	20,000	0.42
114	3,430	0.63	3,600	0.63	7,580	0.63	7,960	0.63	14,660	0.62	20,000	0.49
120	3,110	0.67	3,270	0.67	6,870	0.67	7,210	0.67	13,610	0.67	19,990	0.57
126	2,840	0.70	2,990	0.70	6,260	0.70	6,570	0.70	12,380	0.70	19,010	0.63
132	2,610	0.73	2,740	0.73	5,730	0.73	6,010	0.73	11,310	0.73	17,760	0.67
138	2,400	0.77	2,520	0.77	5,260	0.77	5,520	0.77	10,380	0.77	16,610	0.72
144	2,220	0.80	2,330	0.80	4,850	0.80	5,090	0.80	9,560	0.80	15,560	0.76
150	2,060	0.83	2,160	0.83	4,490	0.83	4,710	0.83	8,830	0.83	14,590	0.80
156	1,910	0.87	2,010	0.87	4,170	0.87	4,370	0.87	8,190	0.87	13,690	0.85
162	1,780	0.90	1,880	0.90	3,880	0.90	4,070	0.90	7,610	0.90	12,860	0.89
168	1,670	0.93	1,750	0.93	3,620	0.93	3,800	0.93	7,100	0.93	12,080	0.93
174	1,570	0.97	1,650	0.97	3,390	0.97	3,550	0.97	6,630	0.97	11,330	0.97
180	1,470	1.00	1,550	1.00	3,180	1.00	3,330	1.00	6,210	1.00	10,600	1.00

STRUCTURAL UNBRACED BEAM CAPACITIES

LENGTH	33H		34H		44H		45H		56H		68H	
	CAP'Y	DEFL	CAP'Y	DEFL	CAP'Y	DEFL	CAP'Y	DEFL	CAP'Y	DEFL	CAP'Y	DEFL
48	11,800	0.17	12,750	0.18	19,590	0.13	20,000	0.12	20,000	0.06	20,000	0.04
54	10,180	0.21	11,040	0.22	16,780	0.16	18,330	0.16	20,000	0.09	20,000	0.05
60	8,880	0.25	9,670	0.26	14,520	0.18	15,920	0.19	20,000	0.13	20,000	0.07
66	7,810	0.30	8,540	0.31	12,670	0.21	13,940	0.22	20,000	0.17	20,000	0.10
72	6,920	0.34	7,600	0.35	11,120	0.24	12,290	0.25	18,370	0.20	20,000	0.12
78	6,150	0.38	6,800	0.40	9,810	0.27	10,890	0.28	16,160	0.22	20,000	0.16
84	5,500	0.42	6,110	0.44	8,670	0.30	9,680	0.31	14,270	0.24	20,000	0.20
90	4,930	0.46	5,510	0.49	7,660	0.32	8,630	0.34	12,630	0.26	18,040	0.22
92	4,750	0.47	5,320	0.50	7,330	0.33	8,310	0.35	12,130	0.27	17,310	0.22
94	4,580	0.48	5,150	0.52	7,020	0.33	8,000	0.36	11,600	0.28	16,490	0.23
96	4,420	0.50	4,980	0.53	6,730	0.34	7,710	0.37	11,100	0.28	15,770	0.23
98	4,260	0.51	4,790	0.54	6,460	0.35	7,410	0.38	10,640	0.29	15,100	0.24
100	4,100	0.52	4,610	0.56	6,200	0.35	7,120	0.39	10,210	0.29	14,470	0.24
102	3,950	0.53	4,440	0.57	5,960	0.36	6,840	0.39	9,810	0.30	13,880	0.24
104	3,800	0.54	4,280	0.58	5,740	0.37	6,580	0.40	9,420	0.30	13,320	0.25
106	3,670	0.55	4,130	0.59	5,520	0.37	6,340	0.41	9,060	0.31	12,800	0.25
108	3,540	0.56	3,990	0.60	5,320	0.38	6,110	0.41	8,730	0.31	12,310	0.26
114	3,190	0.59	3,600	0.63	4,780	0.40	5,490	0.44	7,820	0.33	11,000	0.27
120	2,900	0.62	3,270	0.67	4,320	0.42	4,960	0.46	7,050	0.35	9,890	0.28
126	2,640	0.65	2,990	0.70	3,930	0.44	4,510	0.48	6,390	0.36	8,940	0.29
132	2,420	0.68	2,740	0.73	3,590	0.46	4,120	0.50	5,820	0.38	8,130	0.31
138	2,230	0.71	2,520	0.77	3,290	0.48	3,780	0.52	5,330	0.39	7,420	0.32
144	2,060	0.74	2,330	0.80	3,030	0.50	3,480	0.55	4,900	0.41	6,810	0.33
150	1,910	0.77	2,160	0.83	2,800	0.52	3,220	0.57	4,520	0.43	6,270	0.35
156	1,770	0.80	2,010	0.87	2,600	0.54	2,980	0.59	4,180	0.44	5,790	0.36
162	1,650	0.83	1,880	0.90	2,410	0.56	2,770	0.61	3,880	0.46	5,370	0.37
168	1,550	0.87	1,750	0.93	2,250	0.58	2,590	0.64	3,610	0.47	4,990	0.38
174	1,450	0.90	1,650	0.97	2,110	0.60	2,420	0.66	3,370	0.49	4,650	0.40
180	1,360	0.92	1,550	1.00	1,970	0.62	2,270	0.68	3,150	0.51	4,350	0.41



Selecting Beams and Capacities

Assuming the use of very common flush type pallets, calculations can be made as follows: Multiply the maximum load width (in inches) times the number of loads between uprights. Add 3" to 4" for spacing between each load and uprights. This total is the minimum required beam length. For capacity required, multiply the maximum load weight (include pallet) times number of loads per pair of beams. This total is your capacity requirement per pair of beams. Use the chart to find the beams that meet or exceed your span and capacity requirements.

ROLL FORMED BEAM CAPACITY CHART (Pounds per pair, uniformly distributed load)

LENGTH	KH 26D		KH 32D		KH 36D		KH 41D		KH 44D		KH 47D		KH 52D		KH 60D		KH 60C	
	CAP'Y	DEFL.	CAP'Y	DEFL.	CAP'Y	DEFL.	CAP'Y	DEFL.	CAP'Y	DEFL.	CAP'Y	DEFL.	CAP'Y	DEFL.	CAP'Y	DEFL.	CAP'Y	DEFL.
48	5,430	0.19	6,960	0.16	8,620	0.14	9,970	0.13	11,390	0.12	13,190	0.11	14,000	0.10	14,000	0.07	14,000	0.06
54	4,860	0.24	6,230	0.21	7,720	0.18	8,920	0.16	10,190	0.15	11,800	0.15	12,950	0.13	14,000	0.10	14,000	0.09
60	4,400	0.29	5,640	0.25	6,990	0.22	8,070	0.20	9,230	0.19	10,690	0.18	11,730	0.16	14,000	0.14	14,000	0.12
66	4,030	0.35	5,160	0.31	6,390	0.27	7,390	0.25	8,440	0.23	9,780	0.22	10,730	0.20	13,260	0.17	14,000	0.16
72	3,530	0.40	4,760	0.36	5,900	0.32	6,810	0.29	7,790	0.27	9,020	0.26	9,900	0.23	12,230	0.21	14,000	0.20
78	3,030	0.43	4,420	0.43	5,470	0.37	6,330	0.34	7,230	0.31	8,380	0.30	9,190	0.27	11,350	0.24	13,400	0.24
84	2,630	0.47	3,910	0.47	5,110	0.43	5,910	0.40	6,760	0.37	8,000	0.36	8,590	0.32	10,610	0.28	12,510	0.28
90	2,310	0.50	3,430	0.50	4,800	0.50	5,550	0.45	6,340	0.42	7,500	0.41	8,060	0.36	9,960	0.32	11,750	0.32
92	2,210	0.51	3,290	0.51	4,650	0.51	5,440	0.47	6,220	0.44	7,200	0.42	7,900	0.38	9,760	0.33	11,520	0.34
94	2,130	0.52	3,160	0.52	4,460	0.52	5,330	0.49	6,100	0.46	7,060	0.44	7,750	0.39	9,570	0.35	11,290	0.35
96	2,040	0.53	3,040	0.53	4,290	0.53	5,230	0.52	6,000	0.48	6,930	0.45	7,600	0.41	9,390	0.36	11,080	0.37
98	1,970	0.54	2,920	0.54	4,130	0.54	5,140	0.54	5,870	0.50	6,800	0.47	7,460	0.43	9,220	0.38	10,870	0.38
100	1,890	0.56	2,810	0.56	3,970	0.56	5,010	0.56	5,760	0.51	6,680	0.49	7,330	0.45	9,050	0.39	10,680	0.40
102	1,820	0.57	2,710	0.57	3,830	0.57	4,830	0.57	5,660	0.54	6,560	0.51	7,200	0.46	8,890	0.41	10,490	0.41
104	1,760	0.58	2,610	0.58	3,690	0.58	4,660	0.58	5,560	0.56	6,440	0.53	7,070	0.48	8,740	0.43	10,310	0.43
106	1,700	0.59	2,520	0.59	3,560	0.59	4,490	0.59	5,470	0.58	6,330	0.55	6,950	0.50	8,590	0.44	10,130	0.45
108	1,640	0.60	2,430	0.60	3,440	0.60	4,340	0.60	5,380	0.60	6,230	0.57	6,840	0.52	8,440	0.46	9,960	0.46
114	1,480	0.63	2,200	0.63	3,110	0.63	3,920	0.63	4,860	0.63	5,880	0.63	6,510	0.58	8,040	0.51	9,490	0.51
120	1,340	0.66	2,000	0.67	2,820	0.67	3,560	0.67	4,420	0.67	5,350	0.67	6,220	0.64	7,680	0.56	9,070	0.57
126	1,230	0.70	1,820	0.70	2,580	0.70	3,250	0.70	4,030	0.70	4,880	0.70	5,920	0.70	7,360	0.62	8,680	0.63
132	1,130	0.74	1,670	0.73	2,360	0.73	3,000	0.73	3,700	0.73	4,480	0.73	5,430	0.73	7,060	0.68	8,330	0.69
138	1,040	0.77	1,540	0.77	2,180	0.77	2,750	0.77	3,410	0.77	4,000	0.74	5,000	0.77	6,790	0.74	8,010	0.75
144	960	0.80	1,430	0.80	2,010	0.80	2,540	0.80	3,150	0.80	3,810	0.80	4,620	0.80	6,480	0.80	7,580	0.80
150	890	0.83	1,320	0.83	1,870	0.83	2,360	0.83	2,920	0.83	3,540	0.83	4,290	0.83	6,010	0.83	7,030	0.83
156	830	0.87	1,230	0.87	1,740	0.87	2,190	0.87	2,720	0.87	3,290	0.87	4,000	0.87	5,590	0.87	6,540	0.87
162	770	0.90	1,150	0.90	1,620	0.90	2,050	0.90	2,540	0.90	3,070	0.90	3,720	0.90	5,220	0.90	6,100	0.90
168	720	0.93	1,070	0.93	1,520	0.93	1,920	0.94	2,370	0.93	2,870	0.93	3,490	0.93	4,880	0.93	5,710	0.93
174	680	0.97	1,010	0.97	1,420	0.96	1,800	0.97	2,230	0.97	2,700	0.97	3,270	0.97	4,580	0.97	5,360	0.97
180	640	1.00	950	1.00	1,340	1.00	1,690	1.00	2,090	1.00	2,530	1.00	3,070	1.00	4,310	1.00	5,040	1.00

Structural Beam Part Number

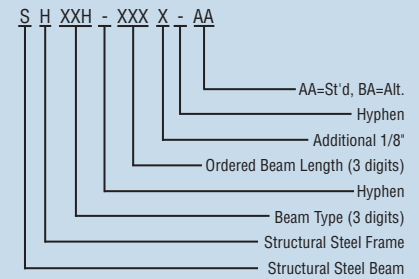

Roll Formed Step Beam Part Number

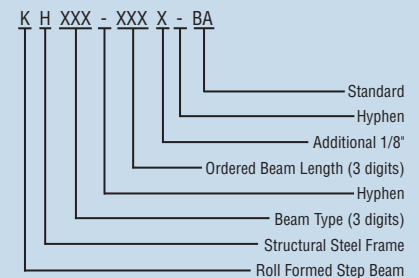

Speedrack Beam Capacity Notes (Structural & Roll Formed)

NOTES:

- Capacities are based on the 2012 RMI Specification, the 2010 AISC Specification and the 2008 AISI Specification.
- Capacities listed are based on a UNIFORMLY DISTRIBUTED load. Contact Engineering for any other loading condition.
- Capacities listed are based on 2-pallet wide storage and include dead load and impact.
- Capacities include semi-rigid beam connections and are valid only with Speedrack, Teardrop or Structural endplates.
- Capacities below the bold line are limited based on L/180 maximum deflection.
- Shaded capacities are limited to 14,000 lbs. per pair of beams when roll formed beam endplates are used.
- Braced beam capacities are based on a single brace located at mid-span.
- For other loading conditions, including seismic, contact Engineering for design and capacities.

Structural Steel Pallet Rack...

...the ideal rack for simplicity of design, heavy load capacity and superb resistance to impact damage.

- Speedrack offers welded structural steel frames with the options of using structural steel beams or formed step beams. With Speedrack you have more choices in selecting which rack structure will best provide maximum strength, quality and economy for your installation.
- Call Speedrack or your local representative to assist you with any information you may require.
 - 3" and 4" welded structural steel frames.
 - High strength steel for 3" and 4" members.
 - Bolted beam-to-frame construction.
 - Beams adjustable on 2" increments.
 - Full range of accessories available.
 - Capacities to fit most applications.

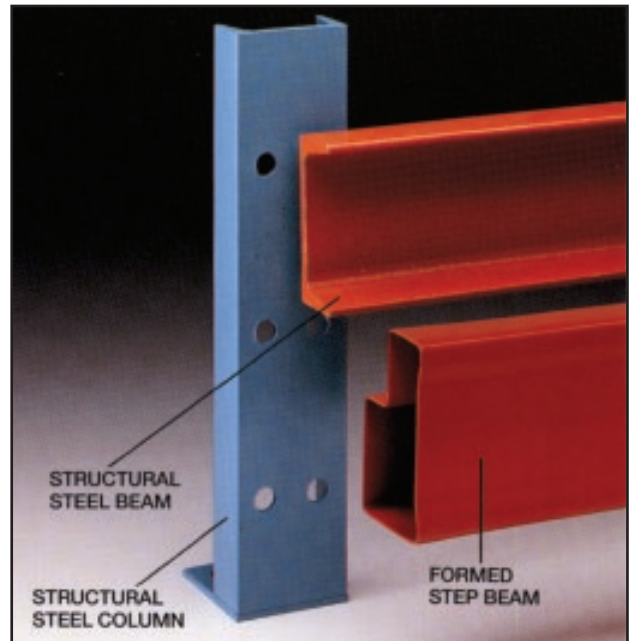

Structural Steel Drive-In Rack FOR MAXIMUM SPACE UTILIZATION

Efficient Speedrack Drive-In Rack greatly reduces the number of lift truck aisles required. Maximum cube utilization is achieved. It is possible to virtually double storage capacity in a given area for outstanding space and money savings.

Speedrack engineering developed drive-in rack and continues to lead the industry in designing the very best rack; achieving the ultimate in strength and safety.

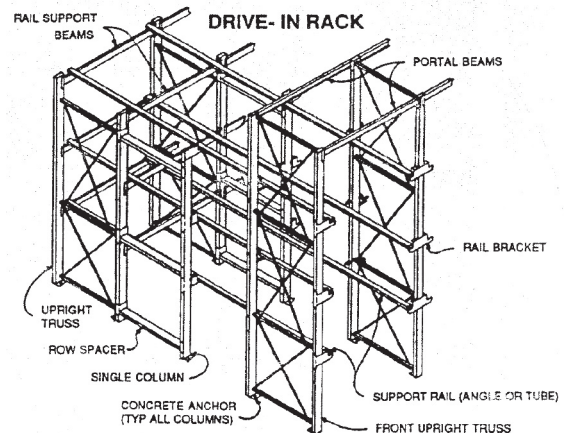

For additional information and specifications on Speedrack Products and services, please contact Speedrack or your local distributor for any of the following brochures:

- Speedrack selective rack
- Speedrack K-1000 (teardrop) selective rack
- Speedrack structural rack
- Speedrack Keystone selective rack
- Speedrack Cantilever rack
- Speedrack drive-in/drive-through rack
- Speedrack furniture cantilever
- Speedrack heavy duty cantilever
- Speedrack Modular Rollback™ / Modular PushBack™
- Cant-leg® upright trusses
- Super Truss® upright trusses
- Rack safety
- Modular Pallet Flow
- Pallet Flow Rails

Information on other products and services is also available upon request. For information visit our Web site at Speedrack.net.

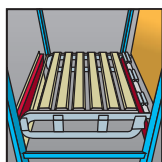

MODULAR PALLET FLOW



SELECTIVE RACK



ENGINEERING



CANTILEVER RACK

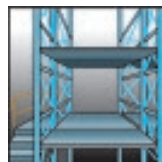

MODULES



RACK SUPPORTED BLDG.

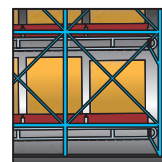

MODULAR ROLLBACK™



FURNITURE CANTILEVER



DRIVE-IN

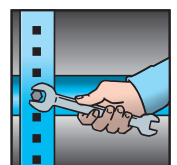

INSTALLATION

Speedrack Products Group, LTD.

7903 Venture Avenue • Sparta, Michigan 49345 • Toll-Free 1-800-752-7352
www.speedrack.net